

## TAGpower Long Range Ridel5000 Reader/Encoder

Technical Manual



Cod.: 120.0011.1 Rev.: 0

July, 2003

## Indice General

1.-INTRODUCTION .....	4
1.1.- OVERVIEW .....	5
1.2.- SYSTEM DESCRIPTION .....	6
1.3.- RIDEL5000 KEY FEATURES .....	7
1.4.- RIDEL5000 VIEWS .....	8
1.5.- SUPPLIED ELEMENTS .....	9
1.6.- NON SUPPLIED ACCESORIES .....	9
2.-FUNCTIONAL DESCRIPTION .....	10
2.1.- RIDEL5000 BLOCK DIAGRAM .....	11
2.2.- EXTERNAL CONNECTION .....	13
2.3.- INTERFACES/INDICATOR DESCRIPTION .....	14
2.3.1.- FRONT PANNEL CONNECTORS .....	14
2.3.2.- REAR CONNECTOR AND INDICATORS .....	14
2.3.3.- INPUT/OUTPUT CIRCUIT .....	15
2.3.4.- OUTPUT CIRCUITS .....	15
3.-COMMAND SET .....	16
3.1.- PC-RIDEL5000 PROTOCOL .....	17
3.1.1.- SERIAL PROTOCOL .....	17
3.1.1.1.- CHARACTER DEFINITIONS .....	17
3.1.1.2.- PROTOCOL DESCRIPTION .....	17
3.1.1.2.1.- COMMAND SEQUENCE .....	18
3.1.1.2.2.- RESPONSE SEQUENCE .....	18
3.1.1.3.- DATA BLOCK FORMATS .....	18
3.1.1.3.1.- HOSTPRIDEL5000 (COMMAND) .....	18
3.1.1.3.2.- RIDEL5000PHOST (RESPONSE) .....	19
3.1.1.3.3.- DESCRIPTION OF THE DATA BLOCK .....	19
3.2.- RIDEL5000 FUNCTIONS .....	21
3.2.1.- SURVEY .....	21
3.2.1.1.- LOW LEVEL FUNCTIONS .....	21
3.2.1.2.- TABLE OF STATUS VALUES .....	22
3.2.2.- RIDEL5000 FUNCTIONS .....	23
3.2.2.1.- ANTICOLLISION/SELECT .....	24
3.2.2.2.- READ .....	25
3.2.2.3.- READ UNSELECTED .....	26
3.2.2.4.- WRITE .....	27
3.2.2.5.- HALT .....	28
3.2.2.6.- RESET QUIET BIT .....	29
3.2.2.7.- EAS FUNCTION .....	29
3.3.- RIDEL5000 COMMANDS .....	30
3.3.1.- RIDEL5000 CONFIGURATION COMMANDS .....	30
3.3.2.- RIDEL5000 STATE COMMANDS .....	30
3.3.3.- EEPROM INICIALIZATION ADDRESSES .....	31
3.4.- TAG-WORLD PROTOCOL .....	32

3.4.1.-	CONTINUOUS READ .....	32
3.4.2.-	READ 32 .....	
3.4.3.-	WRITE .....	32
3.4.4.-	VERSION .....	32
3.5.-	OPERATING MODES .....	33
3.6.-	INIZIALIZATION VARIABLES .....	34
3.7.-	DEFAULT VALUES .....	36
4.-	TECHNICAL SPECIFICATION .....	37
4.1.-	ELECTRICAL SPECIFICATIONS .....	38
4.1.1.-	RADIO .....	38
4.1.2.-	COMMUNICATION .....	38
4.1.3.-	I/O PORTS .....	38
4.1.4.-	POWER SUPPLY .....	38
4.1.5.-	ENVIROMENTAL .....	38
4.1.6.-	CE MARKING .....	38
4.2.-	PHISICAL DIMENSIONS .....	39
5.-	INSTALLATION .....	40
5.1.-	CONTENTS AND UNPACKING .....	41
5.2.-	STORAGE .....	41
5.3.-	INSTALATION .....	42
5.3.1.-	REQUIRED ELEMENTS .....	42
5.3.2.-	POWER SUPPLY/POWER CONSUMPTION .....	42
5.3.3.-	OVERVOLTAGE/REVERSE POLARITY .....	42
5.3.4.-	ANTENNA .....	42
5.3.5.-	MECHANICAL CONSIDERATIONS .....	43
5.3.5.-	COMMUNICATION AND I/OCABLES .....	44
5.3.6.-	STARTUP PROCEDURE .....	44
5.4.-	CABLE CONNECTION EXAMPLES .....	45
6.-	TROUBLESHOOTING .....	46
6.1.-	TEST PROCEDURE .....	47
6.2.-	PRELIMINAR TESTS .....	47
6.3.-	POWER ON .....	47
6.4.-	RF AND COMMUNICATION MEASUREMENTS .....	48
6.5.-	LABEL READING TEST .....	48

## 1.- INTRODUCTION

## 1.1.- OVERVIEW

This chapter provides general information of the RIDEL5000 I-CODE reader-encoder, and associated equipment.

I-CODE protocol is a recent development in the field of Radio-Frequency identification (RFID). It is based in a new chip developed and manufactured by Philips Semiconductors, inside the Albatros european research program. It provides a low cost and high performance solution to any application requiring long-range reading and encoding of information in one or several tags («smart labels») in the working field of one reader-encoder.

The I-CODE smart label includes one I-CODE chip and one antenna. It is powered by means of the electromagnetic field generated by the reader/encoder, and in this situation, it establishes a communication link with the unit. It is possible then, to detect, read or write the chip without any physical or visual contact. The I-CODE protocol incorporates an anti-collision feature, making it possible to simultaneously read and encode several labels in the range of the antenna.

The label incorporates an unique factory-written electronic code, and a non-volatile memory area where it is possible to store information. It can be written up to 100.000 times. It has also an EAS (electronic article surveillance) software activated and deactivated feature.

The whole system operates at the normalized frequency of 13.56MHz.

There are many possible applications for this kind of systems, access control, logistics, retail, point of sale units, manufacturing process control, ...

In POS or retail applications, the system combines the anti-theft capability (EAS), and the product identification, incorporating in one system the benefits of the bar-code marking and the EAS tag anti-theft system.

In logistics applications, the block memory structure makes the I-CODE smart label the best choice for the logistic control of products. Also the multiple write capability, makes it ideal in an application where several users or statements in a company have to deal with the same product. It is possible to add product information in every stage in the manufacturing or handling of the product or set of products.

In the manufacturing control process, its anti-collision feature makes it possible to read or write information in several parts included in the same set, individually, or as a whole, or even in a label fixed in the container. The traceability in the manufacturing process can be achieved by writing all the relevant data in the tag in every step of the process.

## 1.2.- SYSTEM DESCRIPTION

The following figure depicts the block diagram of a minimum I-CODE system including the RIDEL5000 long range reader/encoder and the ANTMR5000 antenna.

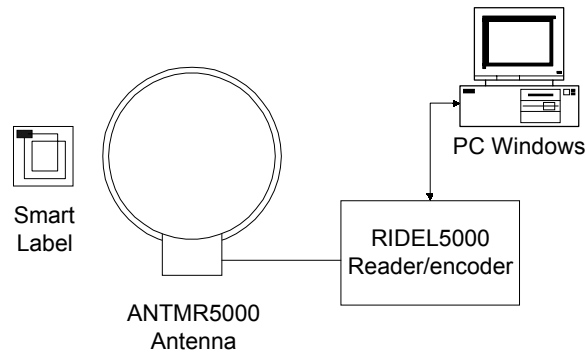

The antenna is used to generate the electromagnetic field needed for the excitation of the transponder chip, and to receive the response of the label. Its proper design is very important to the functionality of the whole system. Many factors have to be considered in the design of the antenna:

- Required operating range
- Length and height of the operating field
- 2D or 3D geometry
- Background material

There are many standard or custom solutions for the antenna. In the picture the ANTMR5000 (a loop antenna for up to 80cm reading/encoding) has been depicted.

The RIDEL5000 is the RF transceiver needed to generate the necessary RF transmitted power, to activate the label and to communicate with it, and to detect and process the tiny received signal from the I-CODE label. It also supports all the communications protocols with the controlling computer.

There is also one computer needed to run the control application (it is possible to configure the RIDEL5000 in a stand-alone mode). This application provides the user interface to control the unit. The RIDEL5000 provides complete information (reading-encoding process, EAS, calibration parameters, real time measurements of temperature, SWR, transmitted power, state of the antenna, ...) through its serial port. It is possible, then, to develop the complete PC application according to the users requirements.

Support libraries have been developed to help system integrators or software developers to generate complete high-level applications.

The I-CODE labels are designed in accordance with the system requirements. There are some standard formats, and it is possible to develop special sizes or materials for special applications. They are composed of a I-CODE chip, an antenna, and a material support.

The I-CODE chip is supplied by several manufacturers. It supports the label «intelligence», and includes the microprocessor, memory, receiver, transmitter, and power supply systems.

The smart label antenna adopts many different forms and sizes, as required by the application. The design process is usually carried out by the label manufacturer, from the user specifications to the definition of the antenna characteristics, the support material, and the final encapsulant.

### 1.3.- RIDEL5000 KEY FEATURES

This section details the key features of the RIDEL5000 long range I-CODE reader-encoder.

- Supports all I-CODE features
  - Anti collision
  - Contactless reading and encoding
  - EAS detection, activation, deactivation
- 1.2m reading distance (with adequate antenna)
- Group / individual label selection
- Complete self-calibration and adjustment under microprocessor support
- Real time measurements of all the relevant working information
  - Transmitted Power
  - SWR
  - Temperature
- Real time control of relevant working parameters
  - Input filter characteristics
  - IF Gain
  - Reception level
- Easy software maintenance. Firmware update capability (FLASH memory program)
- RS232 and RS485 communication ports
- 4 Input and 4 Output I/O port
  - Opto isolated inputs
  - Solid State 6A outputs
- PC Control through software libraries supplied
- Compact and light design

#### 1.4.- RIDEL5000 VIEWS

In the following figure, it is shown the RIDEL5000 upper-front view, where it is possible to see the fan ventilation slots.



In the second figure it is possible to see the front panel with the manufacturer identification label, and the two coaxial antenna connectors.



In the last figure it is shown the rear view of the unit, with the power supply connector, the RS232 port and the I/O and RS485 port. There is also the «activity» and the power indicators.



#### 1.5.- SUPPLIED ELEMENTS

The unit is supplied in a box, with the user manual, warranty and CE conformity declaration.

#### 1.6.- NON SUPPLIED ACCESORIES

As non supplied accesories, we can mention:

- 24Vcc, 1.5A Power Supply.

**WARNING.- To minimize risk of electric shock and warranty proper operation of the unit, the power supply should be certified by UL, VDE, CS. The adapter and the personal computer connected to this product should also be certified. The CE conformity test for the unit has been carried out with the ASTEC SA45-3109 power supply.**

- RS232 cable (DB9 male to DB9 female)
- RS232 cable (DB9 male to DB25 female)
- I/O and RS485 cable (DB15 male)
- Loop Antenna (ANTMR5000 model)
- Door Antenna (ANTLR5000 model)
- I-CODE 5x5cm label
- Test software for RIDEL5000
- Library CD for Windows programming

**2.- FUNCTIONAL DESCRIPTION**

## 2.1.- RIDEL5000 BLOCK DIAGRAM

The RIDEL5000 block diagram is shown in the following figure..

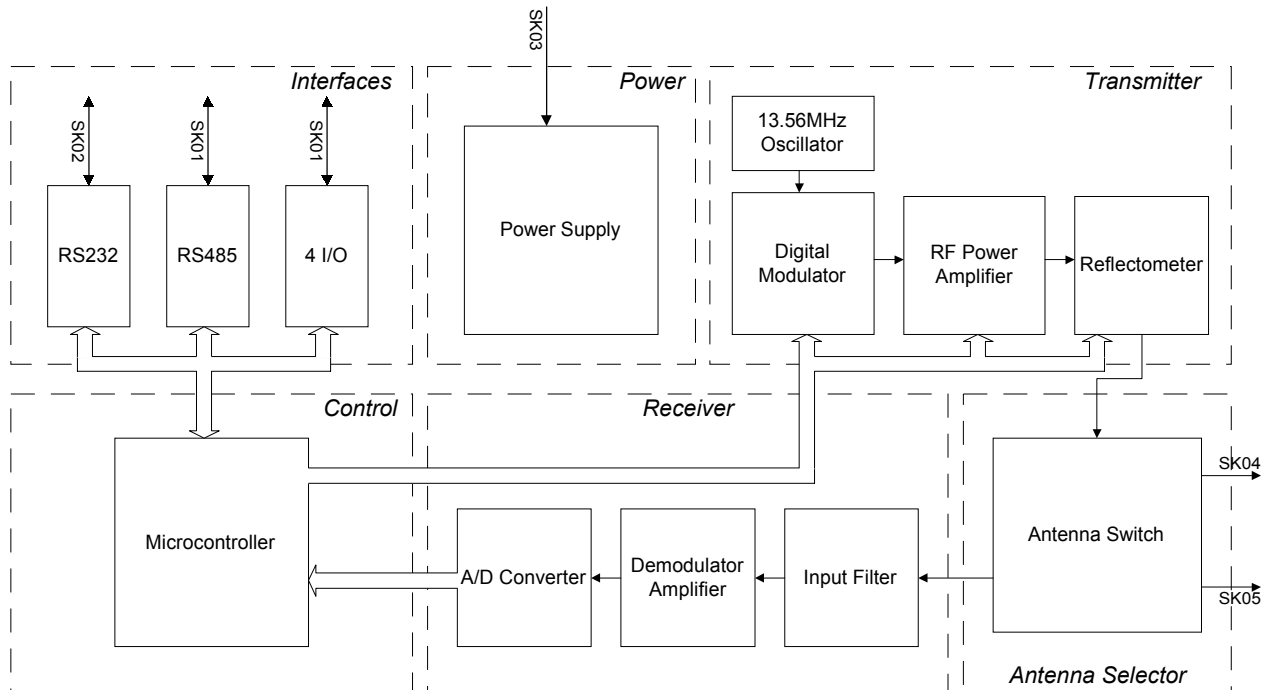

The main blocks or subsystems are:

- The receiver
- The transmitter
- The antenna selector
- The controller
- The I/O interface
- The power supply

The receiver is integrated and encapsulated in a shielded box, to improve its environment noise immunity and its sensibility. It is composed of an input filter, a demodulator, a signal amplifier (all of them with microcontroller adjustment), and an A/D converter to provide information to the microcontroller for measurement and self-calibration purposes.

The transmitter is composed of an oscillator, whose signal is sent to a digital modulator, and a power amplifier with incorporated temperature control. In the transmitter output there is a reflectometer included, giving continuous information to the microcontroller about the transmitted power and the antenna electrical characteristics. It makes it possible to determine SWR and the antenna impedance phase and module.

There is an antenna selector installed between SK03 and SK04 connectors, to select between the one-antenna and two-antennas working modes. (See INSTALLATION chapter).

The whole unit is controlled by means of a microcontroller. It controls the whole radio system, the I-CODE communication protocol, the RS232 and RS485 protocols, and the I/O ports. Its key features are:

- Flash program space. It is possible to modify the internal software through a programming interface provided in the SK02 connector, by means of a special cable and PC software. This makes it possible to update the unit with new versions or different protocols without even opening it.
- Additional memory for stand-alone applications (storage of the read labels data).
- EEPROM for working parameters storage (communication baud rate, default transmitted power, ...)

The external interface is made out of a RS232 port for point to point connections, RS485 port for the parallel connection of several RIDEL5000 units, or other RS485 equipment.

The I/O port consist of 4 input opto-isolated channels, and 4 solid state 6A output channel. It is under microcontroller control, and it can be used to output an alarm signal, to detect movement through a volumetric sensor, ...

The power supply subsystem generates all the internal voltages needed for the unit from the 24Vcc input power source.

## 2.2.- EXTERNAL CONNECTION

The following figure shows the external interface diagram for the RIDEL5000 module.

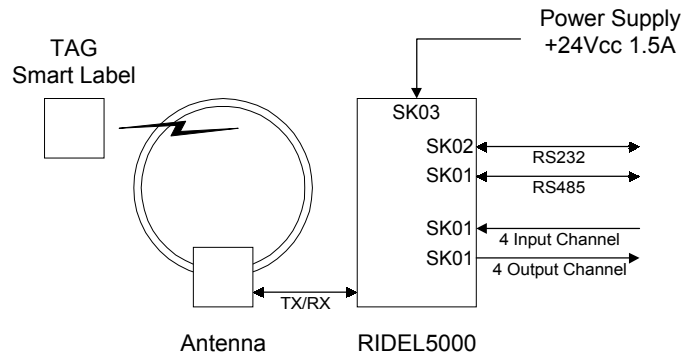

The module can be connected to a computer through its RS232 port. It is possible to select different baud rates up to 115000 bauds.

The RS485 port makes it possible to control several RIDEL5000 units connected to the same bus. The module address or access code is included in the internal EEPROM of the unit.

The communication protocol is described for both interfaces in the COMMAND SET chapter.

The RIDEL5000 also includes one 4-channel I/O port (4 opto-isolate inputs and 4 high current (6A) solid state outputs).

The unit is powered with an external 24Vcc-1.5A power supply, connected to the SK03 port.

The unit has in its front panel, two BNC antenna connectors, so it is possible to configure the RIDEL5000 in the one-antenna or two-antennas (TX-RX) modes, by means of an internal switch (see chapter about INSTALLATION).

## 2.3.- INTERFACES/INDICATOR DESCRIPTION

### 2.3.1.-FRONT PANNEL CONNECTORS

In the module front pannel, there are two RF BNC connectors, intended to connect one or two antennas. The impedance for both input-outputs is 50ohm.

- SK04 Reception antenna (two antennas mode)
- SK05 Transmission antenna (two antennas mode)
- SK04 or SK05 Transmission/Reception antenna (in one antenna mode)

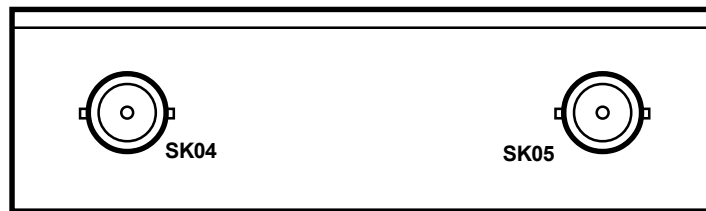

### 2.3.2.- REAR CONNECTOR AND INDICATORS

In the rear of the unit, we can found the following connectors.

#### SK01 RS485 Connector. Auxiliary and programming

1.-	+24Vcc	8.-	Output 3
2.-	Opto-isolated input ground	9.-	Ground
3.-	Programming 2	10.-	Programming 1
4.-	Input 4	11.-	Input 1
5.-	Input 3	12.-	Input 2
6.-	Output 1	13.-	Output 2
7.-	Output 4	14.-	Bus RS485 (A),(+)
		15.-	Bus RS485 (B),(-)

#### SK02 RS232 Connector

2.-	Data Output TXD	5.-	Ground
3.-	Data Input RXD	7.-	RESET

#### SK03 Power Supply

SK03.- Power Supply connector, + inner conductor, - external conductor

#### Indicators

D1.-	Power indicator
D2.-	Activity and state indicator

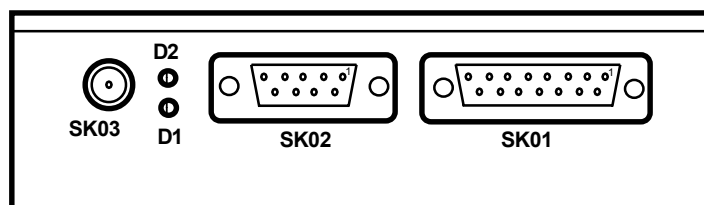

### 2.3.3- INPUT/OUTPUT CIRCUIT

The RIDEL5000 module, has 4 I/O channels (4 INPUT and 4 OUTPUTS) in SK01. The figure shows the input circuit. The circuit is opto-isolated by means of an opto-coupler whose input presents a series limiting resistor. The input circuit ground is common for the 4 channels, and is isolated from the general equipment ground.

The value of the input resistor is calculated to provide 10mA of input current when a 24Vcc voltage is applied to the input terminal.

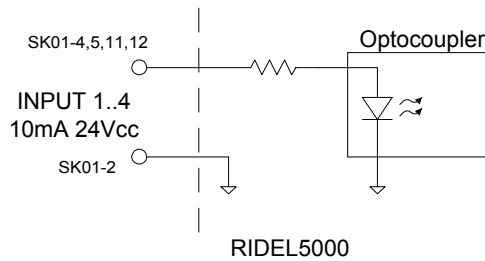

### 2.3.4.- OUTPUT CIRCUITS

The RIDEL5000 module has 4 output channels, as shown in the following figure. They are located in SK01 connector. They are designed with HEXFET N channel transistors, with low internal resistance, configured as open-drain output.

The maximum allowable voltage for any output is 30V. The maximum allowable current is 6.7A.

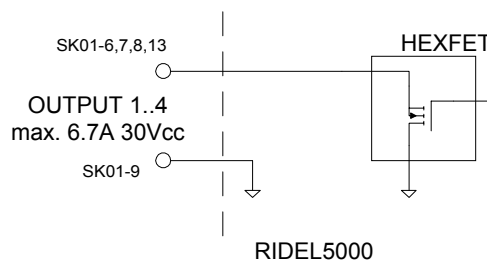

### **3.- COMMAND SET**

### 3.1.- PC-RIDEL5000 PROTOCOL

In this chapter, the serial communication protocol between the host computer and the RIDEL5000 will be described. It is based on the COLIBRI Reader Module Specification Rev. 2.0. from PHILIPS SEMICONDUCTORS.

#### 3.1.1.- SERIAL PROTOCOL

For point to point communications, the RIDEL5000 incorporates a RS232 link with the controlling computer. The communication parameters are defined as follows:

- 8 Data Bits
- One Stop Bit
- No Parity bit

The communication speed is software configurable between 9600 and 115200 baud. The unit is factory configured at 115200 baud.

##### 3.1.1.1.- CHARACTER DEFINITIONS

Description	Char	Value
Start of text	STX	02Hex
End of text	ETX	03Hex
Data link escape	DLE	10Hex
No acknowledge	NAK	15Hex

##### 3.1.1.2.- PROTOCOL DESCRIPTION

To start a communication, the transmitter (at the command sequence this is the host, at the response sequence, this is the RIDEL5000) and the receiver (at the command sequence the RIDEL5000, at the response sequence the host), must be ready. The transmitter starts with STX to establish a data link.

If the receiver answers NAK (or nothing), the transmitter repeats to send STX. If this trial fails again a third (i.e. the last) STX is transmitted to the receiver. If no valid response (DLE) is returned from the receiver, an error message is generated finally, and the transmitter stops to establish a data link.

If the receiver answers DLE within a specified period of time (0.5s), data can be transmitted.

If DLE appears within a data block, it is transmitted twice to distinguish it from the control character DLE.

If the defined maximum character delay (0.5s) is exceeded during transmission of the data block, the receiver returns to the idle state and waits for another STX to establish a new data link.

At the end of transmission of the data block the transmitter transmits DLE and then ETX (DLE is necessary to distinguish a control character from a data byte).

If the receiver detects no error in the transmission (i.e. correct CRC), it answers DLE. If an error is detected, the receiver sends NAK, then the transmitter tries to repeat the entire transmission (maximum two times). If this is not possible it stops sending data and generates an error message.

### 3.1.1.2.1.- COMMAND SEQUENCE

<b>HOST (Transmitter)</b>		<b>RIDEL 5000 (Receiver)</b>
STX	⇒	Receiver Ready?
	⇐	DLE: Yes!
Data[0]	⇒	Start of data block transmission
..		
Data[n]	⇒	
DLE	⇒	Next: Control character
ETX	⇒	End of transmission
	⇐	DLE: No error
		NAK: An error occurred

### 3.1.1.2.2.- RESPONSE SEQUENCE

<b>HOST (Receiver)</b>		<b>RIDEL 5000(Transmitter)</b>
	⇐	STX: Receiver Ready?
DLE	⇒	DLE: Yes!
	⇐	Data[0]: Start of data block transmission
		..
	⇐	Data[n]
	⇐	DLE: Next->Control character
	⇐	ETX: End of transmission
DLE/NAK	⇒	DLE: No error
		NAK: An error occurred

The time in which the receiver has to transmit the control characters upon the transmitter's request is 0.5s. This is also the allowed maximum delay time between two characters during the communication.

### 3.1.1.3.- DATA BLOCK FORMATS

#### 3.1.1.3.1.- HOST⇔RIDEL5000 (COMMAND)

<i><b>TxSeq</b></i>	<i><b>Command</b></i>	<i><b>Len(0)</b></i>	<i><b>Len(1)</b></i>	<i><b>Par(0) ... Par(Len-1)</b></i>	<i><b>CRC16(0)</b></i>	<i><b>CRC16(1)</b></i>
---------------------	-----------------------	----------------------	----------------------	-------------------------------------	------------------------	------------------------

Data(0)    Data(1)    Data(2)    Data(3)    Data(4) Data(Len+3)    Data(Len+4)    Data (Len+5)

<b><i>TxSeq</i></b>	Sequence number of the command	1 byte
<b><i>Command</i></b>	Command code	1 byte
<b><i>Len</i></b>	Number of parameter bytes (low byte, high byte)	2 bytes
<b><i>Par</i></b>	Parameter bytes of command	<b><i>Len</i></b> bytes
<b><i>CRC16</i></b>	16 bit CRC (low byte, high byte)	2 bytes

### 3.1.1.3.2.- RIDEL5000PHOST (RESPONSE)

<i>RxSeq</i>	<i>Status</i>	<i>Len(0)</i>	<i>Len(1)</i>	<i>Res(0) ... Res(Len-1)</i>	<i>CRC16(0)</i>	<i>CRC16(1)</i>
Data(0)	Data(1)	Data(2)	Data(3)	Data(4) Data(Len+3)	Data(Len+4)	Data(Len+5)

<b><i>RxSeq</i></b>	Sequence number of the response	1 byte
<b><i>Status</i></b>	Status byte (serial communication Host-Ridel)	1 byte
<b><i>Len</i></b>	Number of response bytes (low byte, high byte)	2 bytes
<b><i>Par</i></b>	Response bytes	<b><i>Len</i></b> bytes
<b><i>CRC16</i></b>	16 bit CRC (low byte, high byte)	2 bytes

### 3.1.1.3.3.- DESCRIPTION OF THE DATA BLOCK

- A sequence number is generated from the host sent within the data block. After a correct command/response exchange, the host increases the sequence number at the next command. The RIDEL5000 returns always the last received sequence number.

It is recommended that the host application verifies the equality of the sent and received sequence numbers after every command/sequence exchange.

- If the value 10 Hex (DLE) is transmitted within a data block, it is transmitted twice in order to distinguish it from the control character DLE.

The additionally transmitted value 10 Hex is not counted in ***Len***.

- If the value 10 Hex (DLE) is transmitted within a data block, it is transmitted twice in order to distinguish it from the control character DLE.

The additionally transmitted value 10 Hex is not counted in ***Len***.

- The 16 bit cyclic redundancy check character (CCITT-CRC16) is calculated as described in the following:

**Generator Polynom:**  $X^{16} + X^{12} + X^5 + 1$

⇒ CRC\_POLYNOM = 8048 Hex

**Preset Value:**

⇒ CRC\_PRESET = FFFF Hex

**Calculation algorithm (C example)**

```

unsigned int crc=CRC_PRESET;

for (i=0;i<cnt;i++)          /*Command:   cnt=Len+4;*/
                             /*Response:  cnt=Len+6;*/
    {
        crc^=Data[i];
        for (j=0;j<8;j++)
            {
                if (crc & 0x0001)
                    crc=(crc>>1)^CRC_PLOYNOM;
                else
                    crc=(crc>>1);
            }
    }

/* Command */
Data[i]=crc & 0xFF;          /*CRC16 Low Byte*/
Data[i+1]=crc >> 8;         /*CRC16 High Byte*/

/* Response */
if (crc==0)
    {
        /* CRC claculation of response ok */
    }
else
    {
        /* CRC error occurred */
    }

```

The crc variable is set to the preset value only at the beginning of the preparation of a command/response sequence for transmitting to the RIDEL5000/host respectively.

At the command sequence the CRC value is calculated fro the bytes Data[0] .. Data[Len+3] of the data block (including **TxSeq, Command, Len**).

At the response sequence, the CRC value is calculated for all data bytes (Data[0] ... Data[Len+5]) of any response block (including **RxSeq, Status, Len** and both CRC bytes). The resulting CRC value is 0 if no error at transmission occurred.

If a 10 Hex occurs within the data block, 10 Hex is used **once** for the CRC calculation, but transmitted **twice** to the receiver.

### 3.2.- RIDEL5000 FUNCTIONS

#### 3.2.1.- SURVEY

In this chapter, the commands and responses of the RIDEL5000 will be described.

##### 3.2.1.1.- LOW LEVEL FUNCTIONS

Function Name	Command Number	Parameter		Description
		Send	Receive	
CRM_anticoll_select	0x10	hash,tse	resp	Performs the anticollision/select sequence and returns the serial number of each selecte tag
CRM_read	0x11	blnr,nobl	resp	Reads 'nobl' blocks (each of 4 bytes) beginning at the block 'blnr' of all selected tags
CRM_read_unselected	0x12	hash,tse,blnr,nobl	resp	Reads 'nobl' blocks (each of 4 bytes) beginning at the block 'blnr' of all unselected tags in new time slots
CRM_write	0x13	hash,blnr,timeslots,data	resp	Writes one block of 4 bytes to block 'blnr' of all selected tags.
CRM_halt	0x14	hash,timeslots	resp	Sets all selected tags into 'Halt' mode
CRM_reset_QUIET_bit	0x15	-	-	Resets all tags in 'Quiet' mode into 'Idle' mode
CRM_eas	0x16	-	resp	Returns the status of tags in 'EAS' mode ('EAS alarm');

The following functions have no concern with the tags in the fiel (with the exception of the RF off/on).

CRM_config	0x0C	mode,confbyte	-	Changes some RIDEL parameters (depending on <b>mode</b> ), performs an RF off/on sequence ( <b>mode</b> =0, RF off duration=10+4* <b>confbyte</b> (ms)), restarts the initializing of the RIDEL's noise level ( <b>mode</b> =1) or switches on/off the RF permanently ( <b>mode</b> =7, <b>confbyte</b> =1/10)
CRM_get_info	0x0D	mode	resp	Reads the RIDEL current number of time slots ( <b>mode</b> =0) or some firmware information ( <b>mode</b> =1)

### 3.2.1.2.- TABLE OF STATUS VALUES

Name	Value	Description
OK	0	No error at any function or time slot
CRM_NO_TAG	1	No tag in the operating area
CRM_CRC_ERR	2	CRC error at tag communication
CRM_COLLISION	3	Two or more tags answered in the same time slot
CRM_WRONG_SNR	4	Serial number not identical with the expected one in the corresponding time slot
CRM_WEAK_COLLISION	8	Two or more tags answered in the same time slot but the response of one tag was clear
CRM_NO_WRITE_OK	16	Write at the corresponding time slot not performed (according to command)
CRM_NO_HALT_OK	32	Halt at the corresponding time slot not performed (according to command)
CRM_WRONG_PARAMETER	98	Wrong parameter at the given command
CRM_CMD_INTERRUPTED	99	Command interrupted (no response received)
CRM_WRONG_CMD	100	Unknown command
CRM_INIT_ERR	251	Error at function CRM_init()
CRM_COM_STRING_ERR	252	Wrong parameter at function CRM_init()
CRM_FIFO_ERR	253	FIFO buffer error at function CRM_init()
CRM_EXIT_ERR	254	FIFO buffer error at function CRM_exit()
	255	Serial communication error at any function

The possible status values 0 to 32 can be received individually for each corresponding time slot in the response, in contrast to the other status values, which are always returned in byte **Status** (Data (1) of the response).

The status values 8, 16 and 32 can be treated as «no error» since they only deliver additional information. This simply can be done by masking all time slot status values with 7 Hex.

### 3.2.2.- RIDEL5000 FUNCTIONS

In the following, the serial number of a tag is always shown as 64 bit hexadecimal value (e.g. 01 23 45 67 89 AB CD EF Hex).

The location of these eight bytes in the tag's memory are:

Block 0: EF CD AB 89 Hex (Bytes 0,1,2,3 in the first block)

Block 1: 67 45 23 01 Hex (Bytes 0,1,2,3 in the second block)

### 3.2.2.1.- ANTICOLLISION/SELECT

#### Host ⇒ RIDEL5000

Command: 10 Hex  
 Len: 1  
 Par[0] tse: Defines the max. number of time slots  $n = 2^{tse+1}$   
 (0 ... 7 ⇒ 2, 4, 8, 16, 32, 64, 128, 256)  
 hash: Hash value for time slot determination (0...31)

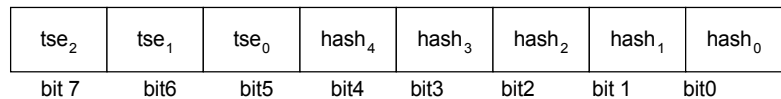

#### RIDEL5000 ⇒ HOST

Len:  $8 \cdot n$  (n: max number of time slots)  
 Resp[0..7]: SNR of tag in time slot 1  
 Resp[8..15]: SNR of tag in time slot 2  
 :  
 Resp[ $8 \cdot (n-1) \dots 8 \cdot n - 1$ ]: SNR of tag in time slot n

The following numbers are **not** valid serial numbers:

00 00 00 00 00 00 00 00 00 Hex ... 00 00 00 00 00 00 00 0F Hex

These numbers are used to transmit special information about the status in the corresponding time slot:

- 00 00 00 00 00 00 00 01 Hex ⇒ No tag
- 00 00 00 00 00 00 00 01 Hex ⇒ CRC error on the RF interface
- 00 00 00 00 00 00 00 02 Hex ⇒ Collision (two or more tags answered in the same time slot)

Others less or equal than

- 00 00 00 00 00 00 00 00 Hex ⇒ Reserved

### 3.2.2.2.- READ

#### Host ⇒ RIDEL5000

Command:	11 Hex	
Len:	2	
Par[0]	blnr: First block to be read	(0..15)
Par[1]	nobl: Number of blocks to be read	(1..16)

#### RIDEL5000 ⇒ HOST

Len:	$n*(1+4*x)$	(n: max number of time slots)
Resp[0]:	Status of time slot 1	
Resp[1]:	Status of time slot 2	
:		
Resp[n-1]	Status of time slot n	
Resp[n..n+3]:	Block m, time slot 1	
:		
Resp [n+4*(x-1)...n+4*x-1]:	Block m+x-1, time slot 1.	
:		
Resp [n+4*x*(n-1)...n+4*x(n-1)+3]:	Block m, time slot n.	
:		
Resp [n+4*(x*n-1)...n+4*x*n-1]:	Block m+x-1, time slot n	

The status byte contain the information concerning possible errors which occurred in the corresponding time slot.

Status:	00 Hex	⇒	No Error
	01 Hex	⇒	No tag
	02 Hex	⇒	CRC Error on the RF interface
	03 Hex	⇒	Collision (two or more tags answered in the same time slot)
	04 Hex	⇒	Weak collision (two or more tags answered in the same time slot, but the response of one tag was clear)

### 3.2.2.3.- READ UNSELECTED

#### Host ⇒ RIDEL5000

Command: 12 Hex  
 Len: 3  
 Par[0] tse: Defines the max. number of time slots  $n = 2^{tse+1}$   
 (0 ... 7 ⇒ 2, 4, 8, 16, 32, 64, 128, 256)  
 hash: Hash value for time slot determination (0...31)

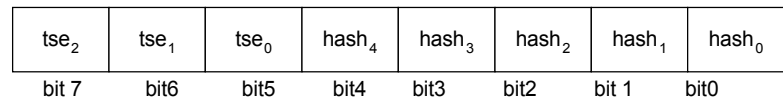

Par[1] blnr: First block to be read (0..15)

Par[2] nobl: Number of blocks to be read (1..16)

#### RIDEL5000 ⇒ HOST

Len:  $n \cdot (1 + 4 \cdot x)$  (n: max number of time slots)

Resp[0]: Status of time slot 1

Resp[1]: Status of time slot 2

:

Resp[n-1] Status of time slot n

Resp[n..n+3]: Block m, time slot 1

:

Resp [n+4\*(x-1)...n+4\*x-1]: Block m+x-1, time slot 1.

:

Resp [n+4\*x\*(n-1)...n+4\*x(n-1)+3]: Block m, time slot n.

:

Resp [n+4\*(x\*n-1)...n+4\*x\*n-1]: Block m+x-1, time slot n

The status byte contain the information concerning possible errors which occurred in the corresponding time slot.

Status:	00 Hex	⇒	No Error
	01 Hex	⇒	No tag
	02 Hex	⇒	CRC Error on the RF interface
	03 Hex	⇒	Collision (two or more tags answered in the same time slot)
	04 Hex	⇒	Weak collision (two or more tags answered in the same time slot, but the response of one tag was clear)

### 3.2.2.4.- WRITE

#### Host ⇒ RIDEL5000

Command:	13 Hex		
Len (rounded off to next integer):	$6+(n+7)/8$		
Par[0]:	hash:	Hash value for acknowledgment	(0..31)
Par[1]:	blnr:	Block to be written	(0..15)
Par[2]:	data[0]:	Byte 0 of block blnr	
Par[3]:	data[1]:	Byte 1 of block blnr	
Par[4]:	data[2]:	Byte 2 of block blnr	
Par[5]:	data[3]:	Byte 3 of block blnr	
Par[6]..Par[Len-1]:	Timeslots:	Information in which time slot the corresponding tag should be written	



:

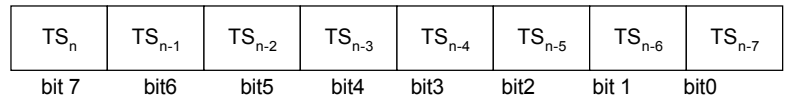

- TS<sub>x</sub> = 0      Function doesn't write to tag in time slot x
- TS<sub>x</sub> = 1      Function writes to tag in time slot x

#### RIDEL5000 ⇒ HOST

Len:	n	(n: max number of time slots)
Resp[0]:	Status of time slot 1	
Resp[1]:	Status of time slot 2	
:		
Resp[n-1]	Status of time slot n	

Status:	00 Hex	⇒	No Error
	01 Hex	⇒	No tag
	02 Hex	⇒	CRC Error on the RF interface
	03 Hex	⇒	Collision (two or more tags answered in the same time slot)
	04 Hex	⇒	SNR is not identical with the expected one in the corresponding time slot
	10 Hex	⇒	'No Write' OK: Tag at corresponding time slot was not written to (according to the command)

### 3.2.2.5.- HALT

#### Host ⇒ RIDEL5000

Command: 14 Hex  
 Len (rounded off to next integer):  $(n+7)/8$   
 Par[0]: hash: Hash value for acknowledgment (0..31)  
 Par[1]..Par[Len-1]: Timeslots: Information in which time slot the corresponding tag should be set in halt mode

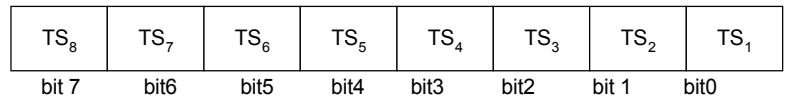

:

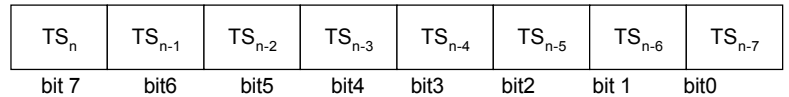

TS<sub>x</sub> = 0    Function doesn't set the tag in time slot x in halt mode  
 TS<sub>x</sub> = 1    Function sets the tag in time slot x in halt mode

#### RIDEL5000 ⇒ HOST

Len: n (n: max number of time slots)  
 Resp[0]: Status of time slot 1  
 Resp[1]: Status of time slot 2  
 :  
 Resp[n-1]    Status of time slot n

Status:

- 00 Hex ⇒ No Error
- 01 Hex ⇒ No tag
- 02 Hex ⇒ CRC Error on the RF interface
- 03 Hex ⇒ Collision (two or more tags answered in the same time slot)
- 04 Hex ⇒ SNR is not identical with the expected one in the corresponding time slot
- 10 Hex ⇒ 'No Halt' OK: Tag at corresponding time slot was not set into halt mode (according to the command)

**3.2.2.6.- RESET QUIET BIT**

**Host ⇒ RIDEL5000**

Command: 15 Hex  
Len: 0

**RIDEL5000 ⇒ HOST**

Len: 0

**3.2.2.7.- EASFUNCTION**

**Host ⇒ RIDEL5000**

Command: 16 Hex  
Len: 0

**RIDEL5000 ⇒ HOST**

Len: 1  
Resp[0]: Status

Status: 00 Hex ⇒ No tag or tag with disabled EAS in the field  
FF Hex ⇒ One or more tags with enabled EAS bit in the field (EAS alarm)

Any value of Status between 00 Hex and FF Hex is possible.

Examples: <40 Hex ⇒ No EAS alarm (caused by disturbances)  
>=40 Hex ⇒ EAS alarm (tag not completely in the field)

### 3.3.- RIDEL5000 COMMANDS

#### 3.3.1.- RIDEL5000 CONFIGURATION COMMANDS

CFG_RF_PAUSE_INIT	0
CFG_INIT	1
CFG_DEFAULT	2
CFG_EAS_LEVEL	3
CFG_EAS_LENGTH	4
CFG_PULSE_OFFSET	5
CFG_PULSE_LENGTH	6
CFG_RF_OFF_ON	7
CFG_FAST_MODE	8
CFG_FAMILY_CODE	9
CFG_APPLICATION_ID	10
CFG_MOD_DEPTH	11
CFG_RF_POWER	12
CFG_FAST_OFFSET	13
CFG_FAST_LENGTH	14
CFG_START_OFFSET	15
CFG_TEST_MODULACION	16
CFG_TUNE_VOLTAGE	17
CFG_AGC	18
CFG_EEPROM	19
CFG_DIR_EEPROM	20
CFG_SAVE_CONFIG	21
CFG_RXFILTER	22
CFG_RF_VALUE	23
CFG_SLICER	24
CFG_RF_ON	25
CFG_RF_OFF	26
CFG_CSTX1	27
CFG_CPTX1	28
CFG_CSTX2	29
CFG_CPTX2	30
CFG_MODE	31
CFG_MEM_INDEX	32
CFG_TX_TUNER	33
CFG_TIME_1	34
CFG_TIME_2	35
CFG_TIME_3	36
CFG_TIME_4	37
CFG_SER_OUT_0	38
CFG_SER_OUT_1	39
CFG_SER_OUT_2	40
CFG_SER_OUT_3	41

#### 3.3.2.- RIDEL5000 STATE COMMANDS

CRM_GET_TIMESLOTS	0
CRM_GET_VERSION	1
CRM_GET_NOISE_LEVEL	2
CRM_GET_MOD_LEVEL	3
CRM_GET_SYS_VARS	4
CRM_GET_MEAS	5
CRM_GET_EEPROM	6
CRM_GET_AD	7

### 3.3.3.- EEPROM INICIALIZATION ADDRESSES

EE_PROTOCOL	11	//1 BYTE
EE_485_ID_H	12	//1 BYTES
EE_485_ID_L	13	//1 BYTES
EE_TUNE_VOLTAGE	14	//2 BYTES
EE_AGC	16	//2 BYTES
EE_POWER	18	//2 BYTES
EE_MOD_INDEX	20	//2 BYTES
EE_REFLECTED_AL	22	//2 BYTES
EE_TEMPERATURE_1	24	//2 BYTES
EE_TEMPERATURE_2	26	//2 BYTES
EE_MODE	28	//1 BYTE
EE_MODE_1	29	//1 BYTE
EE_STAR_OFF	30	//1 BYTE
EE_PULSE_OFF	31	//1 BYTE
EE_PULSE_LEN	32	//1 BYTE
EE_FAST_OFF	33	//1 BYTE
EE_FAST_LEN	34	//1 BYTE
EE_EAS_LEVEL	35	//1 BYTE
EE_EAS_LEN	36	//1 BYTE
EE_CAL_TIME	37	//2 BYTE
EE_SLICER	39	//2 BYTES
EE_BAUDRATE	41	//2 BYTES
EE_ACT_ST_OUT	43	//1 BYTE
EE_MASK_EAS_RD	44	//1 BYTE
EE_RD_LEN	45	//1 BYTE
EE_CSTX1	46	//1 BYTE
EE_CPTX1	47	//1 BYTE
EE_CSTX2	48	//1 BYTE
EE_CPTX2	49	//1 BYTE
EE_CSRX1	50	//1 BYTE
EE_CPRX1	51	//1 BYTE
EE_CSRX2	52	//1 BYTE
EE_CPRX2	53	//1 BYTE

### 3.4.- TAG-WORLD PROTOCOL

#### 3.4.1.- CONTINUOUS READ

**Host ⇒ RIDEL5000** Command: cxx

Where xx is the block number between 0 and 15 in hexadecimal format. Example: 00

**RIDEL5000 ⇒ HOST**

Block 0: 8 bytes hexadecimal +CR +LF

Block 1-15: 4 bytes hexadecimal +CR +LF

Block >15: The whole memory content (64 bytes) +CR +LF

No return if tag is not detected

Example for block 0: EA1E4D0000000001 (serial number)

#### 3.4.2.- READ

**Host ⇒ RIDEL5000** Command: rxx

Where xx is the block number between 0 and 15 in hexadecimal format. Example: 05

**RIDEL5000 ⇒ HOST**

Block 0: 8 bytes hexadecimal +CR +LF

Block 1-15: 4 bytes hexadecimal +CR +LF

Block >15: The whole memory content (64 bytes) +CR +LF

No return if tag is not detected

Example for block 5: AAB01248

#### 3.4.3.- WRITE

**Host ⇒ RIDEL5000** Command: Wxyyyyyyyy

Where xx is the block number between 2 and 15 hexadecimal, and yyyyyyyy are the data to write in hexadecimal format.

**RIDEL5000 ⇒ HOST**

W +CR +LF if operation is correct

N +CR +LF if not

#### 3.4.4.- VERSION

**Host ⇒ RIDEL5000** Commando: x

**RIDEL5000 ⇒ HOST**

Returns information about firmware version. It finishes with +CR +LF

### 3.5.- OPERATING MODES

The RIDEL5000 firmware incorporates different operating modes:

bit 1 a 1	Fast mode
bit 2 a 1	Auto EAS
bit 3 a 1	Auto READ
bit 4 a 1	Auto write
bit 5 a 1	Pass counter
bit 6 a 1	Automatic Tuning Unit control

**Fast Mode.** This is the fast operating mode in the PHILIPS protocol.

**Auto EAS, Autonomous mode.** The RIDEL5000 is looking only for the EAS bit. The selected output port is activated when a tag with EAS bit active is detected.

**Auto READ, Autonomous mode for tag reading.** The memory content of the read tags is stored in the RIDEL5000 memory. All the data can be uploaded to a host when required.

**Auto WRITE, Autonomous mode for reading and writing tags.** The memory content of the read tags is stored in the RIDEL5000 memory. All the data can be uploaded to a host when required.

**Pass counter.** For access control systems. The RIDEL5000 operates with input and output sensors for access control applications.

**Automatic Tuning Unit control.** The RIDEL5000 controls the Automatic tuning units connected to its TX and RX antennas.

### 3.6.- INIZIALIZATION VARIABLES

The variables described here can be modified. They are stored in EEPROM, so that the RIDEL5000 will start with the selected operating parameters.

**IDRS485.** This is the Identification or access code when working in RS485 configuration. Its value can range from 0 to 255.

**Baud Rate.** Serial communication baud rate. It is possible to work with 9600, 14400, 19800, 28800, 56600 or 115200 bauds.

**Communication protocol.** Operating communication serial protocol:

- 0.- PHILIPS compatible protocol
- 1.- ASCII Sofrónica protocol
- 2.- NET Sofrónica protocol
- 3.- TAG-WORLD protocol

**Operating mode.** Mode of operation. It is possible to combine several bits from the following;

- |       |                               |
|-------|-------------------------------|
| bit 1 | Fast mode                     |
| bit 2 | Auto EAS                      |
| bit 3 | Auto READ                     |
| bit 4 | Auto write                    |
| bit 5 | Pass counter                  |
| bit 6 | Automatic Tuning Unit control |

**Output Power.** The output power of the unit is stored here. It is stored as tenths of watt. For instance, 7W is represented as 70, and 3.5W is represented as 35.

**Modulation Index.** Initial modulation index for the transmitter. It is stored as a percentage. For example, a 25 value means a modulation index of 25%.

**Reflected Power Alarm.** Level for reflected power alarm, represented as tenth of watts.

**Temperature Alarm (Half power).** Level for temperature alarm in °C. When the unit reaches this temperature, the output power will be automatically halved..

**Temperature Alarm (0 power).** Level for second temperature alarm in °C. When the unit reaches this temperature, the output power will be automatically set to 0.

**RX Tuning.** Value for RX antenna tuner (between 0 and 255)

**RX Gain.** Intermediate frequency gain setting (between 0 and 255)

**RX Threshold.** Threshold for the RX slicer (between 0 and 255)

**Start Offset.** This parameter sets when the RX signal samples is started. (between 0 and 255)

**Pulse Offset (slow mode).** This parameter sets when the pulses corresponding to time-slots are sampled on the RX protocol in slow mode (between 0 and 255)

**Pulse Length (slow mode).** Slow mode pulse length as a value between 0 and 255.

**Pulse Offset (quick mode).** This parameter sets when the pulses corresponding to time-slots are sampled on the RX protocol in quick mode (between 0 and 255)

**Pulse Length (quick mode).** Quick mode pulse length as a value between 0 and 255.

**EAS Activation level.** Threshold for EAS activation between as a percentage between 0 and 100.

**EAS Activation time.** Sets the activation time for the digital output once the EAS activation level has been reached. It is stored as tenth of seconds. For instance, a 20 in this parameter will activate a digital output during 2 seconds once the EAS activation level has been reached.

**Callibration Interval.** Time in tenth of seconds for the callibration interval.

**Digital Output mask.** Active and inactive state definition of the RIDEL5000 output port. This indicates, for every digital output of the RIDEL5000, its «active» state (active low or active high). It is defined as a mask:

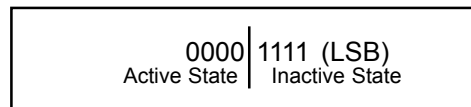

**Digital Output mask for EAS and READ.** Digital Output Port activation mask for EAS or READ VALID operations. The bits with a logic 1, will be activated when the corresponding operation takes place:

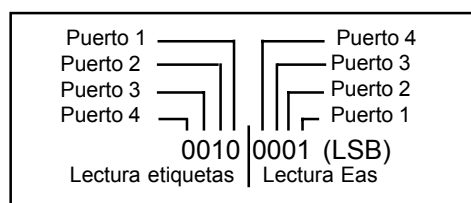

**RD Activation time.** Sets the activation time for the digital output after a valid tag has been read. It is stored as tenth of seconds. For instance, a 20 in this parameter will activate a digital output during 2 seconds once the EAS activation level has been reached.

**ATU Serial Capacitance TX1.** Starting value for the serial capacitance for Automatic Tuning Unit TX 1.

**ATU Paralell Capacitance TX1.** Starting value for the paralell capacitance for Automatic Tuning Unit TX 1.

**ATU Serial Capacitance RX1.** Starting value for the serial capacitance for Automatic Tuning Unit RX 1.

**ATU Paralell Capacitance RX1.** Starting value for the paralell capacitance for Automatic Tuning Unit RX 1.

**ATU Serial Capacitance TX2.** Starting value for the serial capacitance for Automatic Tuning Unit TX 2.

**ATU Paralell Capacitance TX2.** Starting value for the paralell capacitance for Automatic Tuning Unit TX 2.

**ATU Serial Capacitance RX2.** Starting value for the serial capacitance for Automatic Tuning Unit RX 2.

**ATU Paralell Capacitance RX2.** Starting value for the paralell capacitance for Automatic Tuning Unit RX 2.

### 3.7.- DEFAULT VALUES

The factory stored values are:

IDRS485	0
Baud Rate	115200
Communication Protocol	0
Operating Mode	0
Output Power	40
Modulation Index	150
Reflected Power Alarm Level	20
Temperature Alarm Level (1/2 power)	80
Temperature Alarm Level (0 power)	90
RX Tuning value	128
RX Gain	10
RX Threshold	40
Start Offset	8
Pulse Offsett (slow mode)	6
Pulse Length (slow mode)	12
Pulse Offsett (quick mode)	20
Pulse Length (quick mode)	32
EAS Activation level	64
EAS Activation time	20
Callibration interval	60
Digital Output mask	15
EAS and READ Output mask	1
RD Activation time	10
ATU Serial Capacitance TX1	0
ATU Paralell Capacitance TX1	0
ATU Serial Capacitance RX1	0
ATU Paralell Capacitance RX1	0
ATU Serial Capacitance TX2	0
ATU Paralell Capacitance TX2	0
ATU Serial Capacitance RX2	0
ATU Paralell Capacitance RX2	0

## **4.- TECHNICAL SPECIFICATION**

#### 4.1.- ELECTRICAL SPECIFICATIONS

##### 4.1.1.- RADIO

Working Frequency	13.56MHz
Protocol	I-CODE
Transmitted Power	0-10W software adjustable
Receiver sensibility	Better than 20uV
Software Adjustment	Transmitted power, Modulation index, IF Gain, Input Filter
Measurements	Transmitted Power, Reflected Power, SWR, Internal temperature
RF Connectors	2xBNC. One or two antennas configuration

##### 4.1.2.- COMMUNICATION

Communication ports	RS232 / RS485
Baud Rate	9600-115200 baud
RS232 Connector	Standard DB9 Female
RS485 Connector	DB15 Female

##### 4.1.3.- I/O PORTS

N° of input ports	4
Current/Voltage relation	Draws 10mA @ 24Vcc
N° of output ports	4
Max. Current/Voltage	6.7A, 30Vcc

##### 4.1.4.- POWER SUPPLY

Input Voltage	24Vcc $\pm$ 2%
Max. current	1.5A

##### 4.1.5.- ENVIROMENTAL

Working Temperature	-20 to +55°C
Cooling fan incorporated	

##### 4.1.6.- CE MARKING

- EN50081-1 General Electromagnetic compatibility Standar for emissions. Part I. Residential, commercial and light industry.
- EN50082-1 General Electromagnetic compatibility Standaar for Immunity. Part I. Residential, commercial and light industry.

**4.2.- PHISICAL DIMENSIONS**

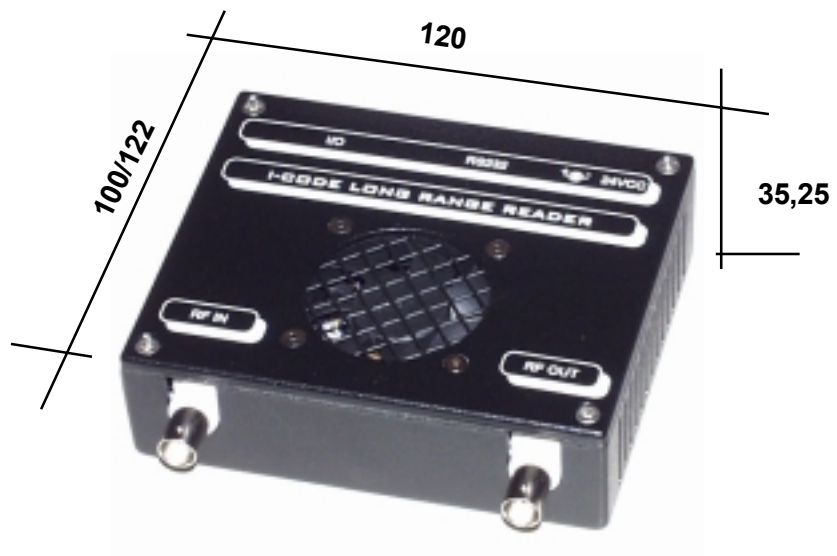
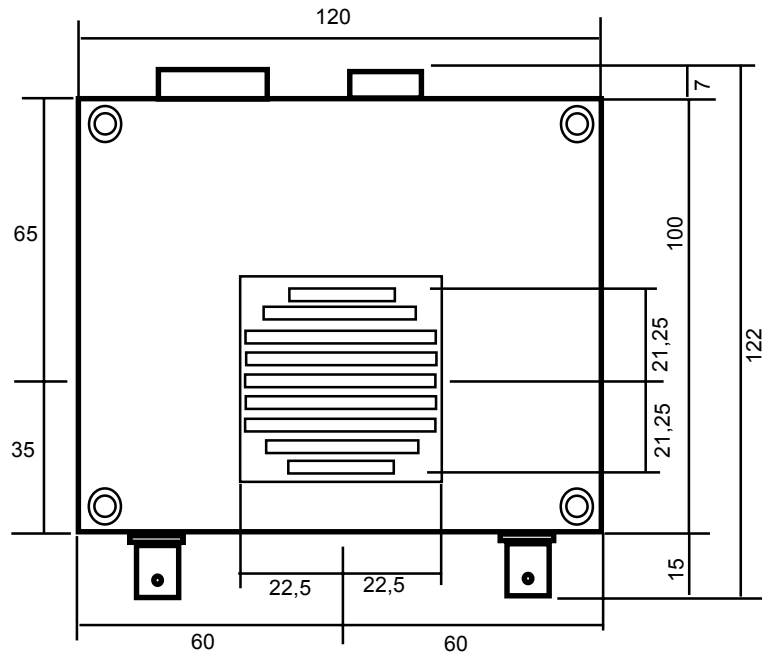

## **5.- INSTALLATION**

## **5.1- CONTENTS AND UNPACKING**

The RIDEL5000 is shipped in a box containing the following elements:

- The RIDEL5000 Module
- The equipment documentation
- The warranty document
- The CE Declaration of Conformity

Before unpacking, please check if the set has suffered any external damage or the unit inside has any flow. In this case, please, contact your distributor to change the unit for a new one.

## **5.2.- STORAGE**

The storage temperature for the equipment has to be kept between -40 and +85°C. Keep it in a dry place.

### 5.3.- INSTALATION

#### 5.3.1.- REQUIRED ELEMENTS

To install the RIDEL5000 with RS232 control, the required elements are:

- The controlling computer or system
- One 24Vcc and 1.5A power supply
- The power supply cables (the mains cord and the unit cable, with + inside)
- Antenna as required and antenna cable.

If the unit is to work with RS485 control, it will also be necessary the RS232 to RS485 adapter (if the final controlling element has a RS232 interface). It will also be necessary to install terminating resistors in the beginning and end of the RS485 bus, as required.

#### 5.3.2.- POWER SUPPLY/POWER CONSUMPTION

Power is supplied to the unit via the power supply connector. The required power supply features are:

Voltage: +24Vcc

Current: +1.5A min

The power is connected to the unit through a 2.5mm jack plug (center +)

**WARNING.- To minimize risk of electric shock and warranty proper operation of the unit, the power supply should be certified by UL, VDE, CS. The adapter and the personal computer connected to this product should also be certified. The CE conformity test for the unit has been carried out with the ASTEC SA45-3109 power supply.**

#### 5.3.3.- OVERVOLTAGE/REVERSE POLARITY

**Before installing the unit is necessary to check the correct polarity and voltage value in the power supply connector. The unit will be damaged if the polarity is reversed or an overvoltage occurs.**

#### 5.3.4.- ANTENNA

The antenna should be the first connected element. The antenna cable length is important to the performance of the unit, and should be considered when designing the antenna. The ANTMR5000 standard medium range antenna requires a 3m coaxial cable to assure its proper operation.

The antenna cable should be coaxial of RG58/U type, with a characteristic impedance of 50 ohm.

The unit is shipped in the one-antenna mode. In this mode, the antenna shall be connected to the RFOUT connector.

If the application requires the configuration of the unit in the two-antenna mode, the unit will have to be opened and a jumper will have to be installed. Follow the next procedure:

- Open the unit by removing the 4 screws that fix the cover of the equipment.
- Install the jumper for the 1 antenna configuration and remove it for TX/RX separated antennas

- Close the unit again, being sure to leave it in the same position as originally (see the fan position for reference)

The position of the jumper can be seen in the following diagram.

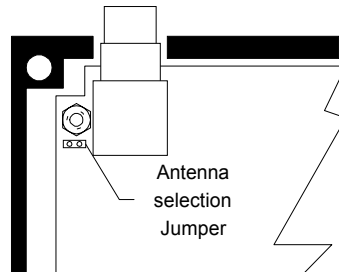

#### 5.3.5.- MECHANICAL CONSIDERATIONS

There are some important considerations to have in mind about the proper physical location of the unit.

- It is necessary to leave a free area around the ventilation slots in both sides of the unit
- It is also necessary not to block the air flow through the ventilation fan

The necessary air gaps are depicted in the following figure.

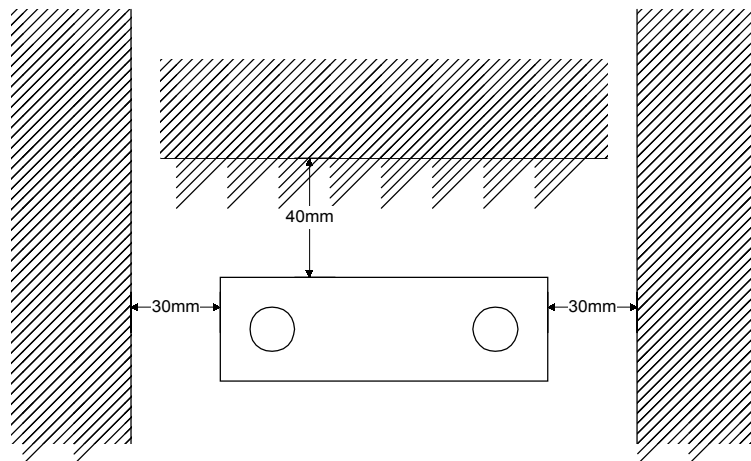

The unit incorporates four drill holes in the base, with M3 thread, and 3mm depth. The drilling diagram is depicted in the following figure.

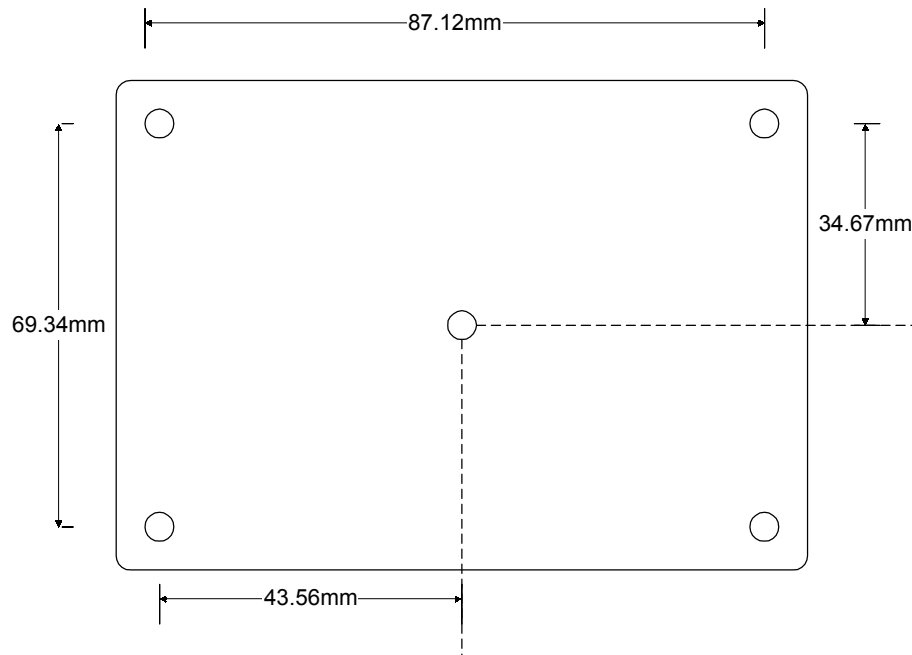

### 5.3.5.- COMMUNICATION AND I/O CABLES

The RS232 cable for a PC connection will have the following pin connections:

<b>RIDEL5000</b> SUBD 9V M	<b>PC</b> SUBD 9V H
2 -----	2
3 -----	3
5 -----	5

The RS485 and I/O cable will be configured as follows:

<b>RIDEL5000</b> SUBD 15V M	
11 -----	INPUT 1
12 -----	INPUT 2
5 -----	INPUT 3
4 -----	INPUT 4
9 -----	GROUND INPUT
6 -----	OUTPUT 1
13 -----	OUTPUT 2
8 -----	OUTPUT 3
7 -----	OUTPUT 4
2 -----	GROUND OUTPUT
14 -----	A (+) RS485
15 -----	B (-) RS485

### 5.3.6.- STARTUP PROCEDURE

The following steps (in this order) should be followed when installing the unit.

- Connect the antenna cable and the antenna
- Connect the mains cord to your power supply (if necessary)

- Connect the communication and I/O cables as required
- Plug the power supply connector into the RIDEL5000

Be sure that the antenna cable and conexions are correct before powering the unit.

Once connected, the power indicator will light permanently, and the «activity» indicator will flash signaling the correct finishing of the self-test routine.

#### 5.4.- CABLE CONNECTION EXAMPLES

In the following diagram it is possible to see the RS232-one antenna configuration mode:

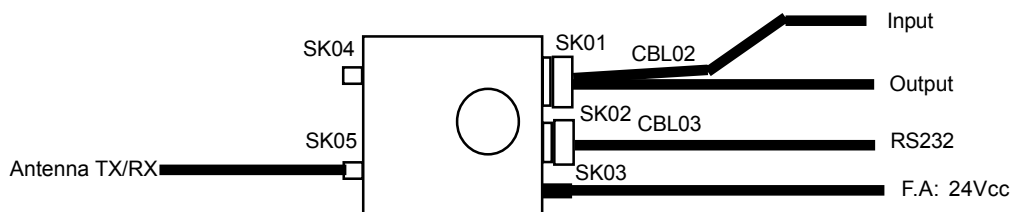

The RS485-two antenna mode can be seen in the following diagram:

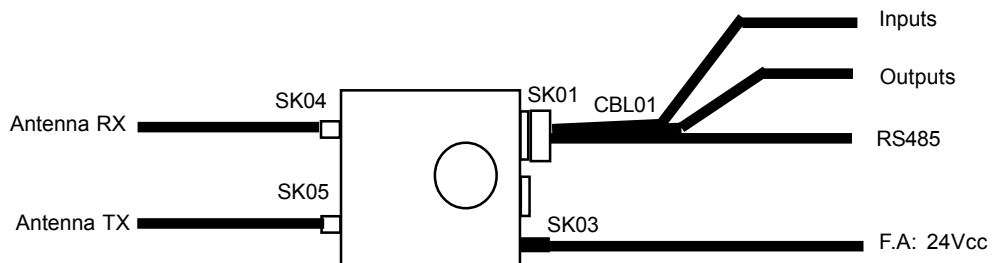

## **6.- TROUBLESHOOTING**

### 6.1.- TEST PROCEDURE

The procedure to test the unit doesn't require any special measurement equipment. It is only necessary to verify some standard points in any RF system to check.

### 6.2.- PRELIMINAR TESTS

As described in the INSTALLATION chapter, before connecting the RIDEL5000, it will be necessary to pay special attention to the Power Supply voltage and polarity in the power plug. The voltage will be 24Vcc and the polarity will be as depicted in the case and in the following diagram.

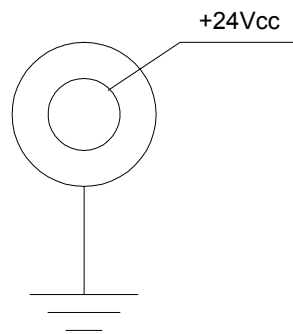

The antenna connection will also be checked. It is important to have in mind that the cable connection with the antenna is relevant to the unit performance. The cable should be supplied by the antenna manufacturer, or it will be built according to its technical specifications.

**WARNING.-** The antennas developed for RFID systems are calculated to work with this type of equipment. It is not recommended to connect radiocommunication antennas or other models not defined by RFID equipment manufacturers or suppliers. The connection of non adequate equipment in the antenna connectors, can cause damage to the unit.

### 6.3.- POWER ON

When connecting the unit, the first event to observe is the ON state in the «power» LED (D1). The «activity» LED (D2) will also flash indicating the proper equipment operation. See the LED position in the following diagram.

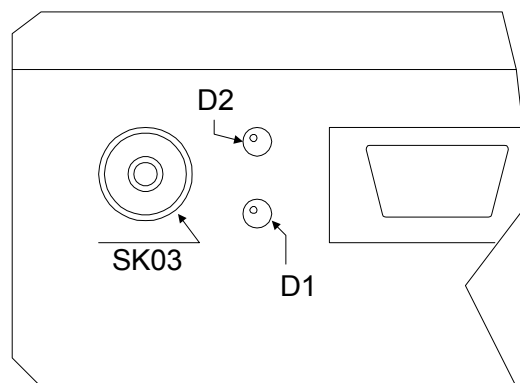

#### **6.4.- RF AND COMMUNICATION MEASUREMENTS**

With the control system connected, check the communication link between the computer and the RIDEL5000. It will be necessary to use your own control program or any diagnostic software, like the one included in the Softrónica's KRFID5000 I-CODE Starter Kit.

If it is possible to have a RF Power Meter, for 13.56MHz, check the Incident Power, the Reflected Power, and so, the coupling between the RIDEL5000 and the antenna.

**WARNING.- The Reflected Power will not exceed the 3W level. A higher reflected power indicates a damage or decoupling in the antenna. In this situation, the RIDEL5000 will try to protect itself and its operation will not be correct. The continued connection of the RIDEL5000 in this condition, can cause damage to its RF circuits.**

If you have a diagnostic computer program, as the one supplied by Softrónica in the KRFID5000 I-CODE Starter Kit, it will be possible to check the same measurements in the «TX Measurements» window.

#### **6.5.- LABEL READING TEST**

Check the proper operation of the equipment by reading some I-CODE labels in EAS and random reading modes. You can do it by placing a label near the antenna and watching the results in your computer application.

It is possible to check it with the diagnostics computer program supplied by Softrónica in its KRFID5000 I-CODE Starter Kit, in the «RX Measurements» window.

